

PRODUCT	TYPE
Wellness lounger	RLX Satori

### Description

Binaural Acoustic and Dynamic Stimulation are the hallmarks of this wellness lounger. As a vibroacoustic wellness therapy, the Satori is designed to harmonize body and mind by synchronizing brainwave patterns and targeted vibration on the body. This wellness therapy promotes relaxation, effortless meditation, and improved sleep hygiene and cognitive performance. The combination of specifically placed transducers, throughout the lounger, together with its design concept, work on focused parts of the body, for a deeply therapeutic Wellness experience. The user can enjoy voice-guided meditation, and non-verbal musical programs that have been created using the latest knowledge in the scientific literature. These touchless therapies support positive mood states, and aid in the regulation of behavior. Documented benefits include positive stress management, and relief from anxiety, sleep issues – as well as addiction recovery support and substantial wellbeing improvement.

Access height: 42 cm (16.5 in) // Projection length: 190 cm (74.8 in) // Width: 70 cm (27.6 in)

Load capacity of the table surface: 160 kg (353 lbs)



### Options against surcharge:

Ferrari Stamskin - special color	181,70 €
Metal parts - special color	483,00 €

### Basic colors without surcharge:

Upholstery	Stamskin Dark Grey
Metal parts	titanium RAL 9007, white RAL 9016, black-brown RAL 8022

	price per piece
Basic price	19.803,00 €

Voice guided meditation modules

Weightless experience for maximum relaxation and mental wellness

Supports mood, and relieves stress, anxiety and depression

The effortless way to meditate



### Gharieni certifications according to ISO13485:

CE marked

Made in Germany

TÜV certification



The above-mentioned prices are to be understood net, **EXW Moers, Germany** (excl. transport, delivery, fees, installation, certification costs)  
**3 years full warranty (on all components), 5 years on actuators, 10 years on metal frames**

PRODUCT	TYPE
Wellness lounger	RLX Satori

**The Satori Programs**

The Satori System offers a selection of nine programs, each with available 4 to 6 sessions. There are four programs that are non-verbal, and five programs that are voice-guided, all in English.

All the relaxation and meditation programs guide brainwaves from ranges of alpha to theta levels. The behavioral change programs utilize the theta brainwave level, where the conscious mind is “shut down,” and the subconscious mind remains active, to deliver guided meditation programs to the subconscious, creating the conditions for lasting behavioral change. The sleep and power nap programs are deep delta level programs that support the mind mitigate stressful cycles of repetitive thinking and promote states of deep delta sleep.



**BREATHE – Meditation through breathwork**  
(non-verbal)

Breathe is series of six meditation sessions with non-verbal breath work reminders embedded. The program is designed so that people with language differences can enjoy the program without having to overcome the language barrier.



**CHAKRA Alignment Meditation:**  
(non-verbal)

A series of six sessions designed to align each Chakra of the body, while guiding brainwaves to a deep meditative state.

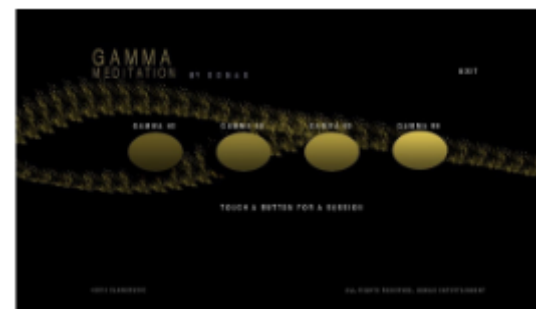

**GAMMA Meditation:**  
(non-verbal)

A series of four Gamma wave sessions for better focus, memory retention and mental clarity.

The Gamma Meditation program involves Gamma brainwaves, which improve cognitive function and memory and are associated with compassion and gratitude.



**Vibrational Wellness:**  
(Two guided, two non-guided programs)

A series of Two guided, two non-guided sessions ranging from 16 minutes to 50 minutes, focusing on mind/body wellness and healing.



**Meditation Energy:**  
(voice guided)

A series of 6 sessions ranging from grounding and stress reduction to energetic cleansing and mind-body regeneration.



**Sleep Wave:**  
(non-verbal)

The Sleep Wave program offers two sessions. They range from programs for relaxation, meditation, sleep, positive self-image, brain fitness and behavioral change

Two sessions designed to guide the brainwave patterns to levels of deep sleep (delta-state). Re-train the brain to quickly adjust from “thinking” mode to deep sleep when it is time to go to sleep at night. At the end of the program the user is brought back to the beta-state, refreshed and rejuvenated.



**Satori Sound Change – Tobacco Cessation Support:**  
(voice guided)

A series of four behavioral change sessions to be used in succession.



**Satori Sound Change – Recovery Support:**  
(voice guided)

A series of four behavioral change sessions to be used in succession.



**Satori Sound Change – Weight Management Support:**  
(voice guided)

A series of four behavioral change sessions to be used in succession.

**Gharieni certifications according to ISO13485:**

- CE marked
- Made in Germany
- TÜV certification



The above-mentioned prices are to be understood net, **EXW Moers, Germany** (excl. transport, delivery, fees, installation, certification costs)  
**3 years full warranty (on all components), 5 years on actuators, 10 years on metal frames**



PRODUCT	TYPE
Wellness lounger	RLX Satori

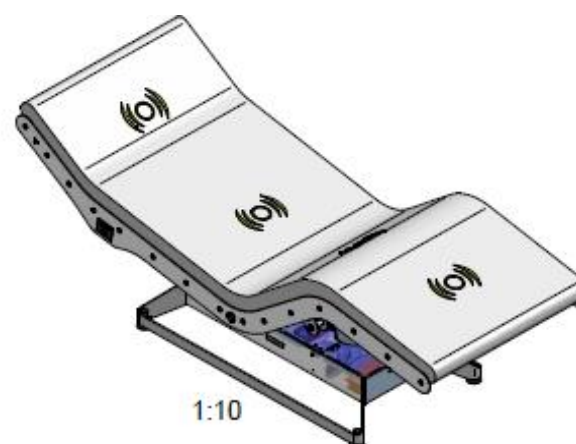
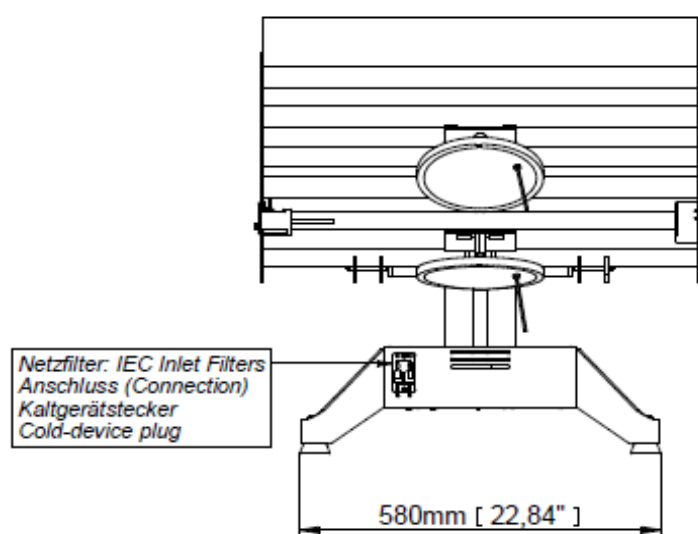
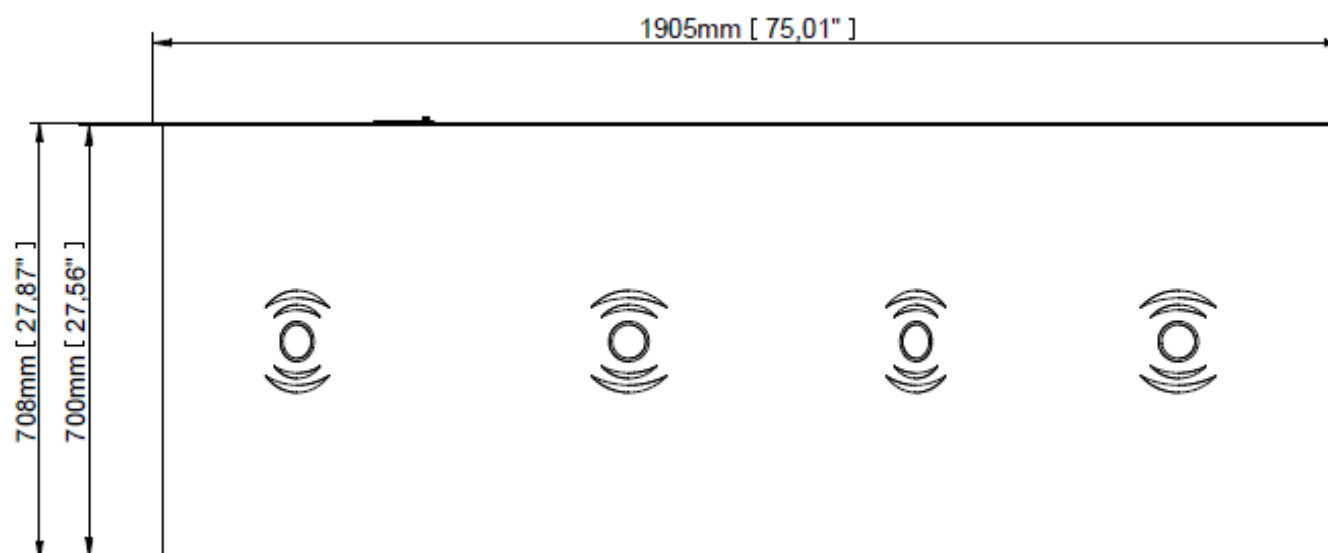
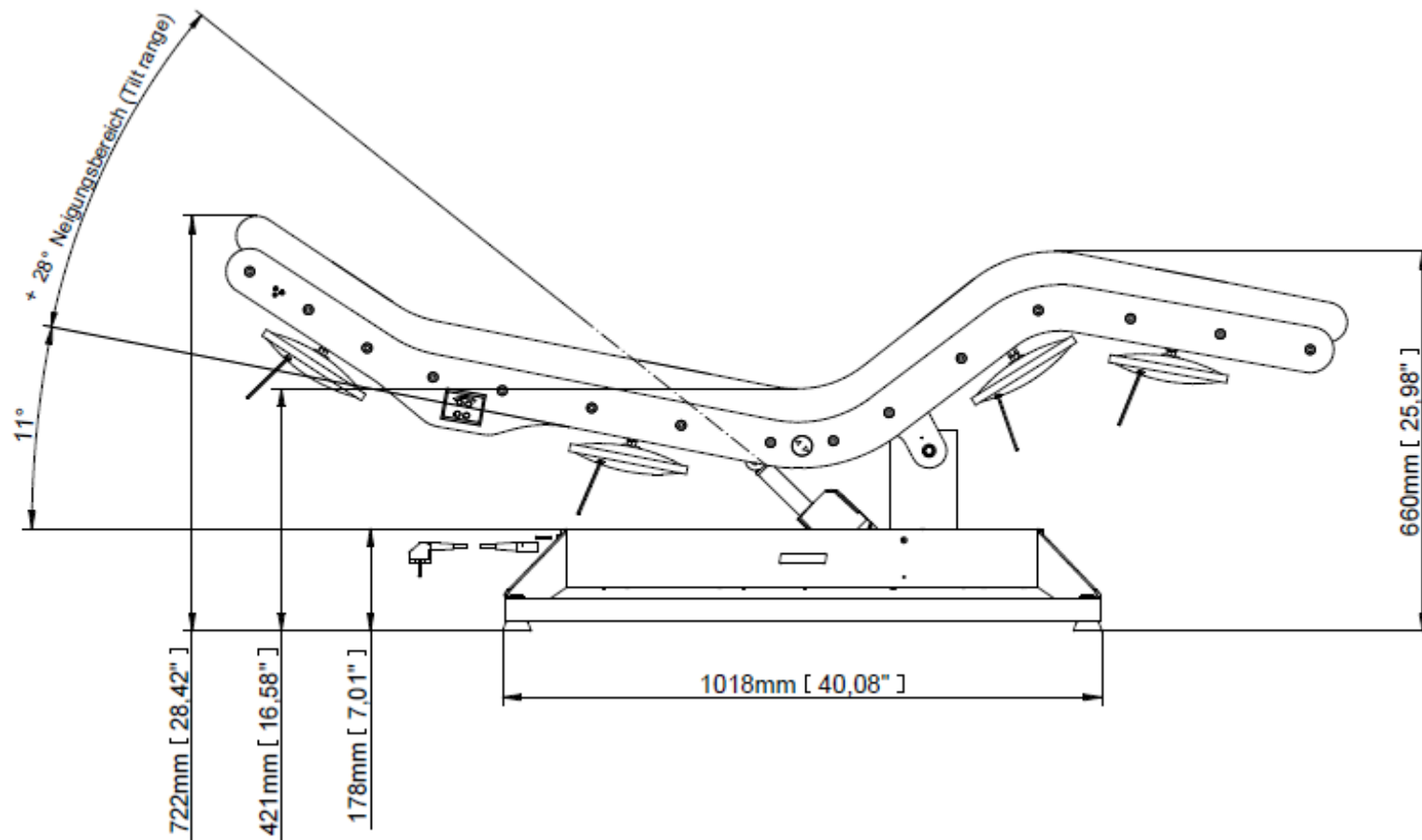

**Gharieni certifications according to ISO13485:**

CE marked  
 Made in Germany  
 TÜV certification



The above-mentioned prices are to be understood net, **EXW Moers, Germany** (excl. transport, delivery, fees, installation, certification costs)  
**3 years full warranty (on all components), 5 years on actuators, 10 years on metal frames**